

## Technical data

Technical data	operation when directly connected to chimney
Energy label	<b>A</b>
<b>Operating data</b>	
Nominal heat power	10 kW
Efficiency	> 80 %
Consumption of wood	3 kg/h
Total heat output of the burning chamber	----
Mass flow of flue gas	9 g/s
Required chimney pressure	12 Pa
Required amount of combustion air	30 m <sup>3</sup> /h
<b>Average flue gas temperature</b>	
on the output	265 °C
<b>Heat distribution</b>	
fireplace insert	54-65 %
door glass (single / double)	46 / 35 %
additional accumulation mass	----
<b>Information for ventilated builds</b>	
Minimal grill area supply / outgoing	1200 / 1400 cm <sup>2</sup>
Minimum distance from insulated areas / floor	80 / 0 mm
Reference insulation <sup>2</sup> ceiling / back wall / side wall / floor	120 / 0 / 80 / 0 mm
Calciumsilicate insulation <sup>3</sup> ceiling / back wall / side wall / floor	90 / 0 / 60 / 0 mm
<b>Information for non-ventilated builds (closed grills)</b>	
Minimum radiant area <sup>4</sup>	suitable
Minimum distance from insulated areas / floor	80 / 20 mm
Reference insulation <sup>2</sup> ceiling / back wall / side wall / floor	160 / 0 / 100 / 20 mm
Calciumsilicate insulation <sup>3</sup> ceiling / back wall / side wall / floor	120 / 0 / 75 / 20 mm
<b>General technical information</b>	
Total weight / lining weight	circa 250–370 / 105 kg
Burning chamber dimensions (width x depth)	810 x 315 mm
Combustion air connection	Ø 150 mm
Use in non-ventilated accumulation builds according to craft rules	suitable
Tested according to	EN 13229
Meets values	BlmSchV (Stufe2), 15a BVG

1 Listed value from testing. For accurate results is evaluation of each system in the Ortnr / KOV program necessary

2 Mineral wool according to AGI-Q 132

3 Example SkamoEnclosure Board 225 kg/m<sup>3</sup>

4 Depends on accumulation period and material characteristics. Listed values calculated with average specific heat output = approx. 500 W/m<sup>2</sup>

# HAKA 89/45T

Technical data  
Version 09/2023

## HAKA 89/45 tunnel door version liftdoor / liftdoor

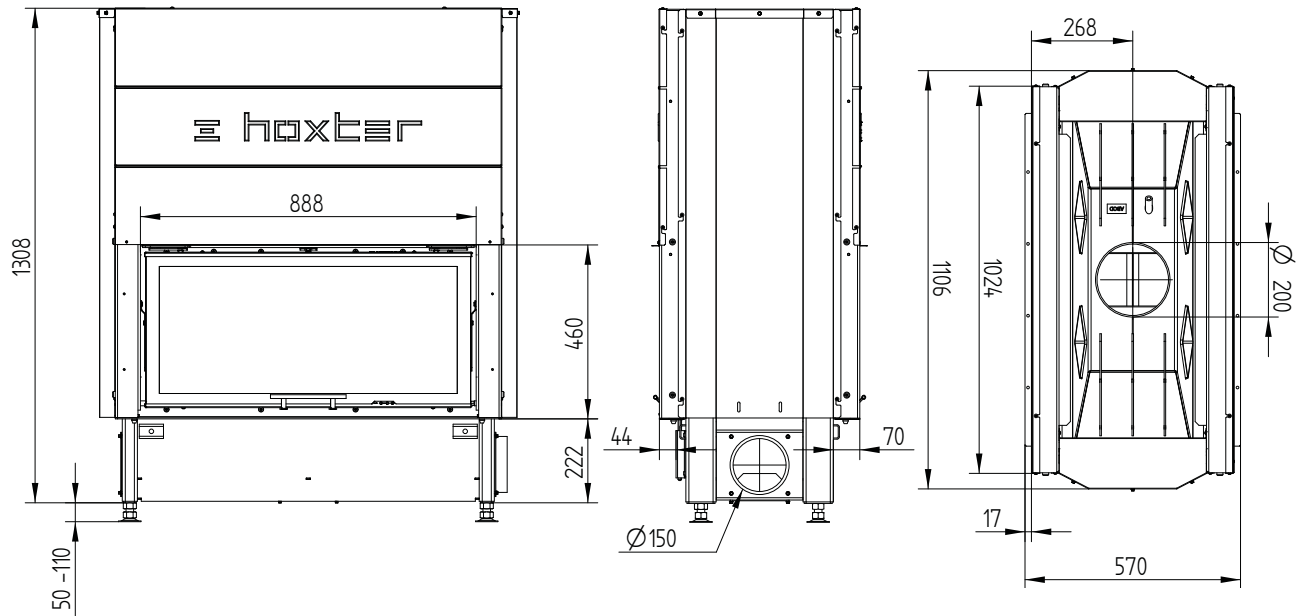

## HAKA 89/45 tunnel door version liftdoor / side opening

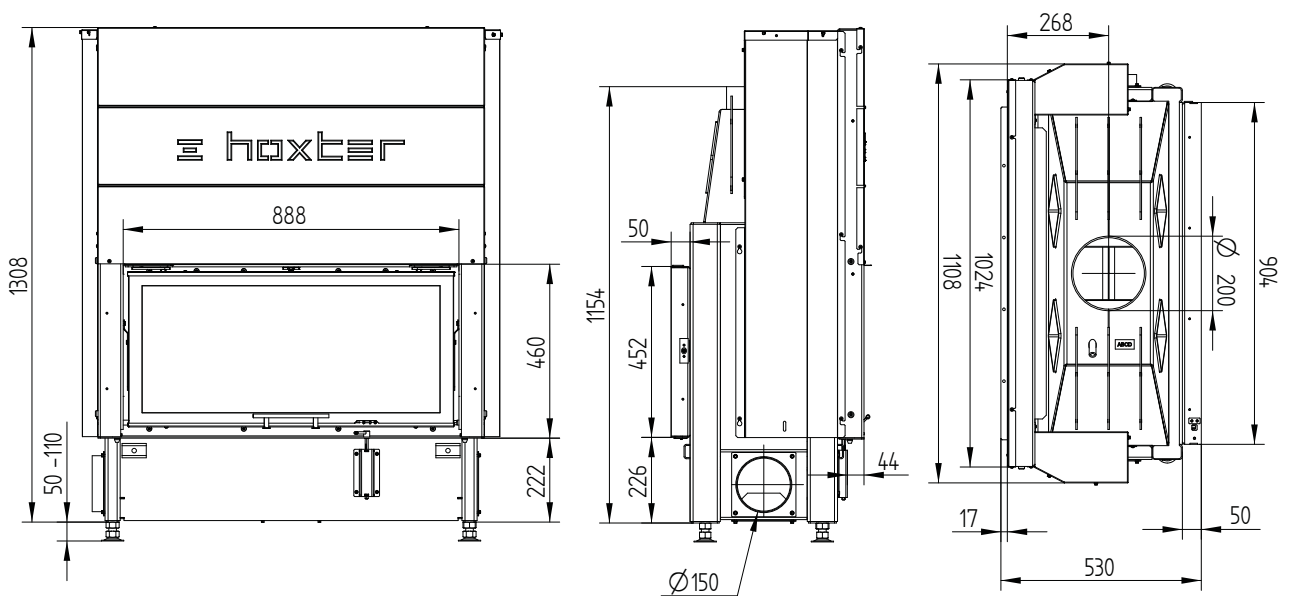

# HAKA 89/45T

Technical data  
Version 09/2023

## HAKA 89/45 tunnel door version side opening / side opening

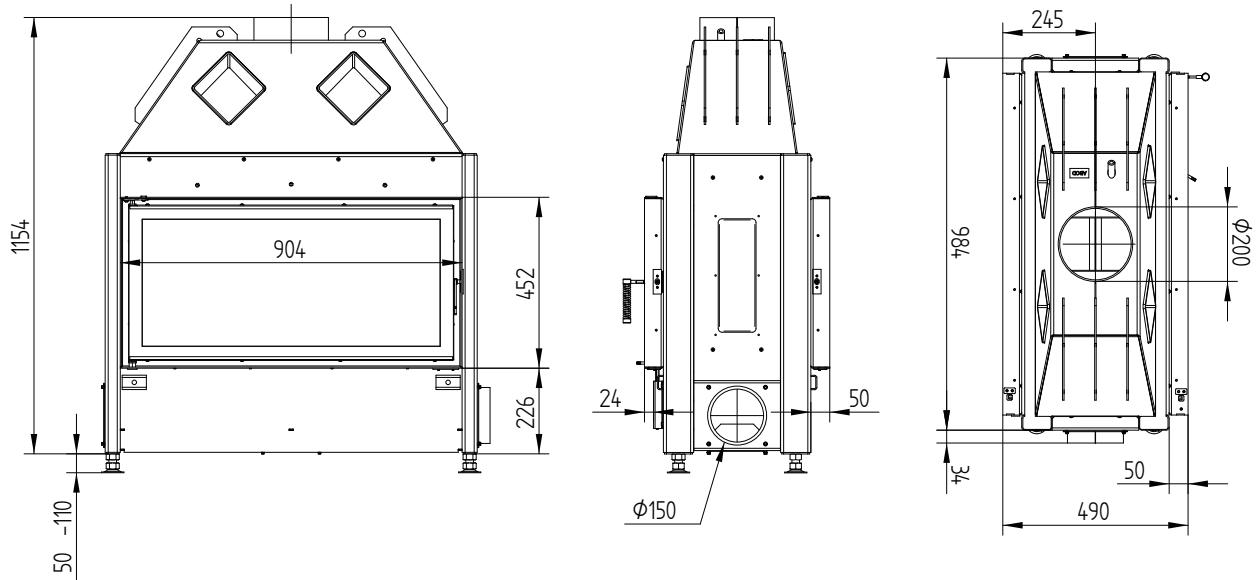

# HAKA 89/45T

Technical data  
Version 09/2023

Cover frame 89/45 4sides 1 x 90°, 50 mm

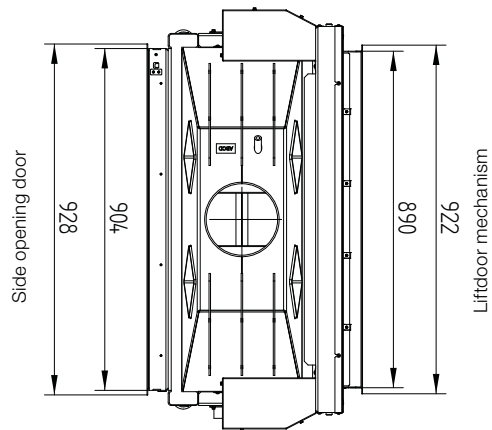
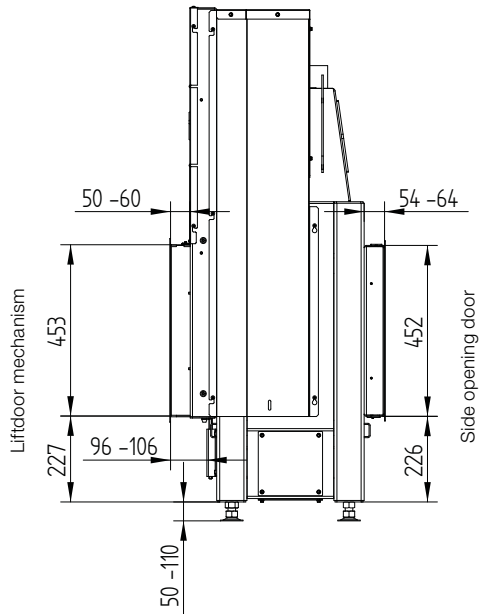
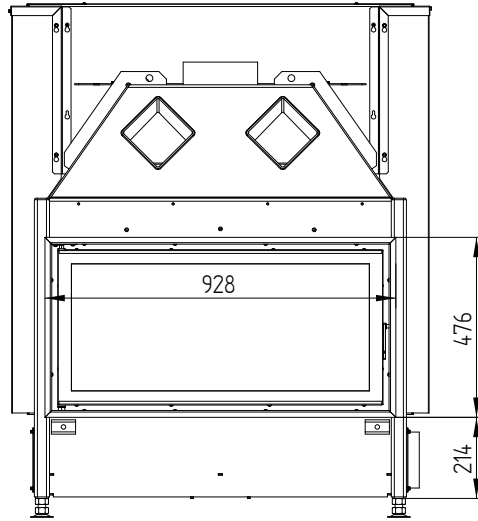
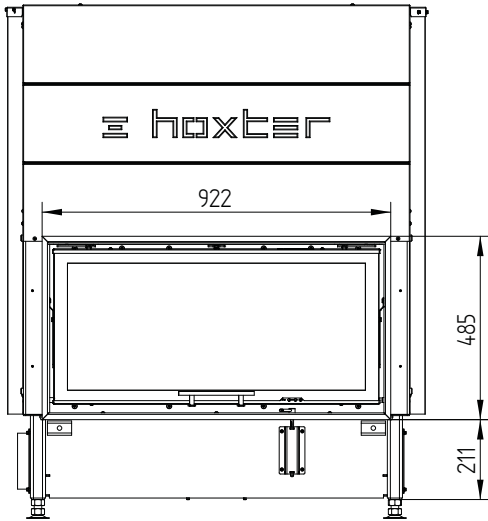

# HAKA 89/45T

Technical data  
Version 09/2023

Cover frame 89/45 4sides 1 x 90°, 80 mm

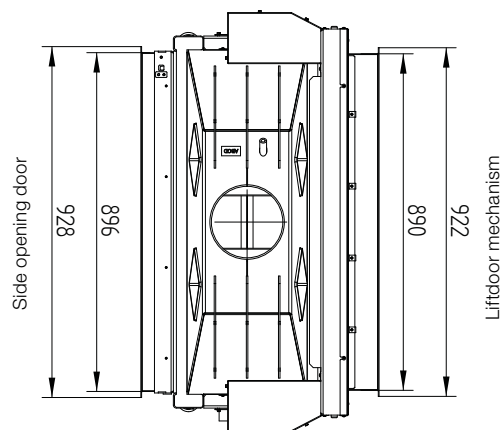
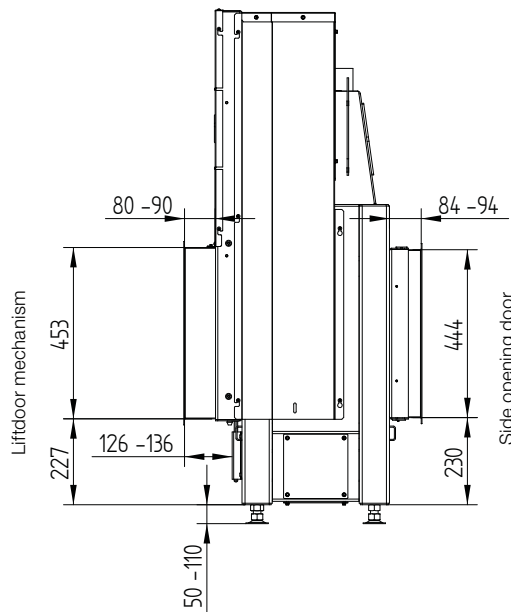
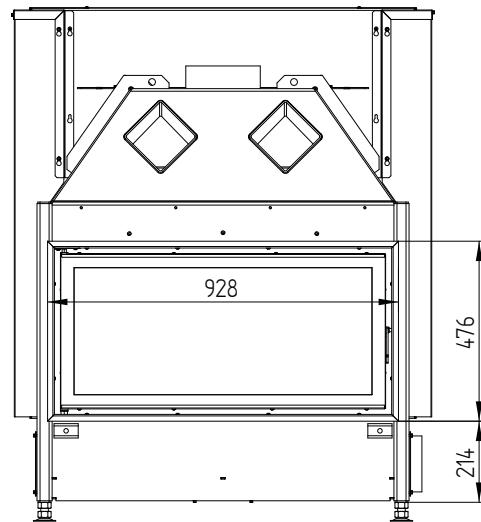
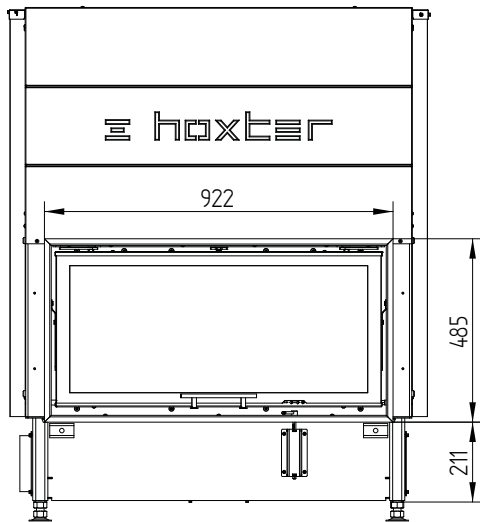

# HAKA 89/45T

Technical data  
Version 09/2023

## Build-on frame 89/45 4sides, 50 mm

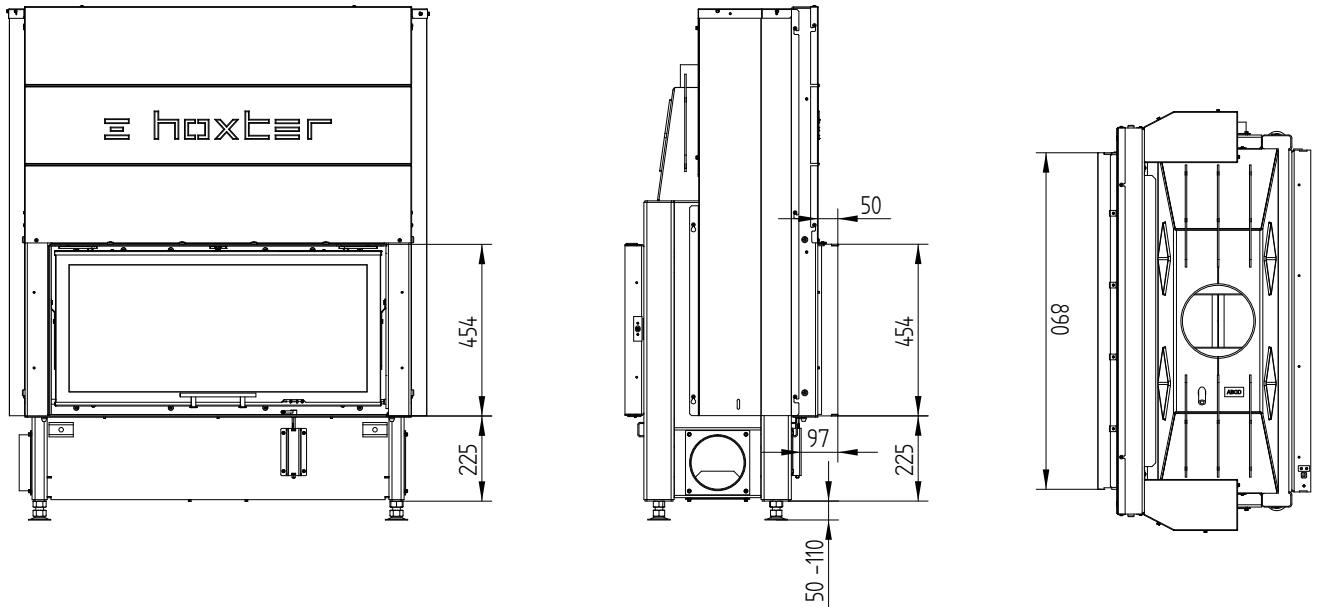

## Build-on frame 89/45 4sides, 80 mm

